

Compressor refrigerators

Unbeatable performance

Home-like cooling comfort

Equipped with Danfoss high-tech compressors, the well-proven refrigerators in the WAECO CoolMatic series provide outstandingly intensive, long-lasting refrigeration for mobile applications. Their operation is totally reliable even in tilted positions and high ambient temperatures. They work economically, extremely quietly, and on solar energy, too.

The various models of the CoolMatic series satisfy all requirements an on-board refrigerator has to meet. There's a matching appliance for every kind of boat or yacht and for every kind of room. The interior features compare extremely favourably well with your domestic fridge too ...



Elegant design to please even the most discerning eye: brushed stainless steel finish outside, frosty Cool Blue illumination inside.

Cool cockpit: all Bavaria motor yachts are supplied as standard with WAECO built-in refrigerators.

WAECO CoolMatic

Refrigerators and freezers

Gross capacity
Voltage
Average power consumption
Freezer
Interior light
Removeable decor panel yes / no
Door vent mechanism
Built-in dimensions (W x H x D)
Weight

CRP-40	CRF-50	CR-50 / CR-50 CHROME
approx. 39 litres	approx. 47 litres	approx. 48 litres
12 / 24 volts DC	12 / 24 volts DC	12 / 24 volts DC
approx. 40 watts	approx. 45 watts	approx. 40 watts
5.3 litre freezer compartment	47 litre *** freezer	5 litre *** freezer compartment
no	yes	yes
yes	yes	yes
yes	yes	yes
380 x 534 x 492 mm	448 x 528 x 488 mm	380 x 534 x 447 mm
18 kg	approx. 25 kg	approx. 19 kg
Page 36	Page 37	Page 41

WAECO CoolMatic

Refrigerators and freezers

Gross capacity
Voltage
Average power consumption
Freezer
Interior light
Removeable decor panel yes / no
Door vent mechanism
Built-in dimensions (W x H x D)
Weight

RSD-115	RSF-115	HDC-150L
approx. 115 litres	approx. 115 litres	approx. 147 litres
12 / 24 volts DC	12 / 24 volts DC	12 / 24 volts DC and 100 - 240 volts AC
approx. 45 watts	approx. 50 watts	approx. 70 watts
-	approx. 115 litre *** freezer	-
yes	yes	yes
-	-	-
yes	yes	-
528 x 744 x 507 mm	528 x 744 x 507 mm	595 x 820 x 550 mm
approx. 28.5 kg	approx. 28.5 kg	approx. 27.5 kg
Page 45	Page 45	Page 47

CR-65 / CR-65 CHROME	CR-80 / CR-80 CHROME	CR-110 / CR-110 CHROME	CR-140 / CR-140 CHROME
approx. 64 litres	approx. 80 litres	approx. 108 litres	approx. 136 litres
12 / 24 volts DC	12 / 24 volts DC	12 / 24 volts DC	12 / 24 volts DC and 100 - 240 volts AC
approx. 45 watts	approx. 48 watts	approx. 50 watts	approx. 65 watts
7.2 litre *** freezer compartment	7.9 litre *** freezer compartment	10.2 litre *** freezer compartment	11.5 litre *** freezer compartment
yes	yes	yes	yes
yes	yes	yes	yes
yes	yes	yes	yes
448 x 525 x 492 mm	475 x 640 x 475 mm	520 x 745 x 505 mm	525 x 805 x 569 mm
approx. 20 kg	approx. 23 kg	approx. 28 kg	approx. 32 kg
Page 41	Page 42	Page 42	Page 43

HDC-150FF	HDC-150DF	HDC-190	HDC-220	HDC-270
approx. 120 litres	approx. 105 litres	approx. 165 litres	approx. 218 litres	approx. 281 litres
12 / 24 volts DC and 100 - 240 volts AC	12 / 24 volts DC and 100 - 240 volts AC	12 / 24 volts DC	12 / 24 volts DC	12 / 24 volts DC and 110 - 240 volts AC
approx. 60 watts	approx. 70 watts	approx. 75 watts	approx. 80 watts	approx. 120 watts
approx. 17 litres	approx. 105 litre *** freezer	approx. 40 litres	approx. 41 litres	approx. 61 litres
yes	-	yes	yes	yes
-	-	-	-	-
-	-	-	-	-
595 x 820 x 550 mm	595 x 820 x 550 mm	550 x 1210 x 580 mm	550 x 1435 x 580 mm	545 x 1780 x 550 mm
approx. 30.5 kg	approx. 31 kg	approx. 33 kg	approx. 42 kg	approx. 50 kg
Page 47	Page 47	Page 49	Page 49	Page 49



Small and smart at a good price

Compact refrigerator, elegant looks

Its matt-silver door panel catches the eye. Designed for smaller yachts and boats, the new CoolMatic CRP-40 adds an elegant touch to the galley. Inside, it's amazingly spacious: 39 litres cooling capacity, including a generously sized freezer compartment. Well-proven compressor technology makes for excellent cooling results, tailor-made installation frames for a flawless finish.

WAECO CoolMatic CRP-40

Premium built-in refrigerator in stainless steel finish for yachts, boats, motorhomes and caravans

4.24





Gross capacity	approx. 39 litres including 5.3-litre freezer compartment
Voltage	12 / 24 volts DC
Average power consumption	approx. 40 watts
Average running time	23% at +20°C ambient temperature, 35% at +32°C ambient temperature, both at +5°C interior temperature
Current consumption	Power input x average running time
Insulation	CFC-free polyurethane foam
System	Fully hermetic Danfoss BD35F compressor with integrated control electronics, low-voltage protection, electronic fuse/automatic reverse pole protection, aluminium rollbond evaporator, mechanically continuously variable thermostat, statically ventilated wire tube condenser
Material	Stainless steel fittings, plastic interior, body of coated sheet steel
Colour	Body: black, door frame: silver, door panel: matt-silver (brushed stainless steel appearance)
Weight	18 kg
Quality features	Door with magnetic seal, variable door mounts and locks right / left, door with double lock (top/bottom) and dual function (locking/ventilation), easy-to-change decor panel. Where space is limited, the cooling unit can be fitted up to 1.5 m away from the refrigerator.
Test marks	CE, TÜV/GS, e-approved to 2006/28/EC (Automotive EMC Directive)

 Normal refrigeration and freezer compartment

 Suitable for solar operation

 Easy-to-change decor panel

 Right-hinged door as standard

 Standard or flush-mount installation frame available as accessory

 Ideal in confined spaces: The cooling unit can be fitted separately

Product	Ref. No.
CoolMatic CRP-40	9105600001
Standard installation frame	EST-0050E
Flush-mount installation frame	EFM-0050E
Additional optional extra	
Mains adapter 110 – 240 V > 24 V	MPS-35

Built-in dimensions (without door, mm) with / without cooling unit:
380 x 534 x 492 / 380 x 534 x 310
With standard frame with / without cooling unit:
384 x 536 x 492 / 384 x 536 x 310
With flush-mount frame with / without cooling unit:
406 x 536 x 545 / 406 x 536 x 363

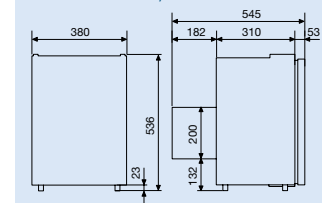

Single or side-by-side partner

Separate freezer CRF-50

Too little space for frozen food in your on-board refrigerator? Place the CoolMatic CRF-50 freezer by its side! Thanks to its special construction the compact unit provides a generous 47-litre capacity for deep-freezing. Its chic stainless steel looks make it a perfect match for the CoolMatic CR-65 refrigerator. Great as part of a combo – really useful on its own.

WAECO CoolMatic CRF-50

*** freezer with 47 litres capacity

4.24



Gross capacity	approx. 47 litres
Voltage	12 / 24 volts DC
Average power consumption	approx. 45 watts
Average running time	45% at +20°C ambient temperature, 65% at +32°C ambient temperature, both at -18°C interior temperature
Current consumption	Power input x average running time
Insulation	CFC-free polyurethane foam
System	Fully hermetic Danfoss BD35F compressor with integrated control electronics, low-voltage protection, electronic fuse / automatic reverse pole protection, dynamically ventilated wire tube condenser, aluminium rollbond evaporator foamed from behind, manually adjustable deep-freeze thermostat
Material	Fittings in stainless steel, door frame in plastic, body with coated metal frame
Colour	Body: black, door frame: silver, door panel: matt-silver (brushed stainless steel appearance)
Weight	approx. 25 kg
Quality features	Condensation drain, interior light, door with magnetic seal, variable door hinges and locks (right / left), door with double lock (top / bottom) and dual function (locking / ventilation), easy-to-change decor panel
Test marks	CE, TÜV/GS, e-approved to 2006/28/EC (Automotive EMC Directive)

Built-in dimensions (W x H x D)
448 x 528 x 488 mm (without door)
With standard frame:
448 x 528 x 492 mm
With flush-mount frame:
474 x 528 x 540 mm

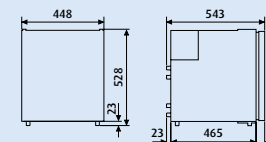

Product	Ref. No.
CoolMatic CRF-50	CRF-0050E
Standard installation frame	EST-0065E
Flush-mount installation frame	EFM-0065E
Additional optional extra	
Mains adapter 230 V > 24 V	EPS-100W
Mains adapter 110 – 240 V > 24 V	MPS-35



Deep-freezing up to -18°C



Easy-clean plastic interior with condensation drainage

Easy-to-change decor panel

Right-hinged door as standard

230-volt connection with low-priced mains adapters (p. 62 – 65)



Comfort feature: the recessed door grip Refrigerator closed Refrigerator in "vent" position Standard or flush-mount frame – whichever you prefer



CoolMatic CR-110

- 1 Double door lock, top and bottom
- 2 Separately insulated *** freezer compartment
- 3 Functional surfaces and trays
- 4 Interior light
- 5 Recessed door grips
- 6 Bottle holder
- 7 Condensation drainage via hose connection or collection tank

Functional eye appeal

Elegant design to please even the most discerning eye: **brushed stainless steel finish** outside, frosty Cool Blue illumination inside. The well organised interior provides a capacity of **48 to 136 litres**, depending on the model. Ease of use enhanced with clever extras such as **bottle holders** and **storage trays**, both open and closed.

A sparkling sight

Premium fridges in stainless look or chrome finish

The exclusive CoolMatic CR refrigerators are designed for people who like to travel First Class. Whether in elegant matte-silver or in the luxurious chrome finish, CoolMatic CR is setting new standards in terms of design, equipment, technology and finish.

Treat yourself to first-class refrigeration – you’re worth it. Take the CoolMatic CR on board and enjoy the same exclusive cooling convenience you have at home!



Premium design with Cool Blue light inside

You prefer to travel in style? The high quality finish and high-grade interior of CoolMatic CR refrigerators is very impressive. First-class materials, sparkling surfaces and the aesthetic Cool Blue interior light are all part of the elegant CoolMatic CR design. A feast for the eye.



Recessed door grips

Comfort to get hold of: the recessed door grips allow for gentle and easy opening of CoolMatic doors. Slightly lifting the grip is enough to unlock the door. You can feel the difference: there is no protruding handle to catch yourself on. Slim grips blend harmoniously with the elegant design of the refrigerator doors.



Functional cooling space

The interior design of CoolMatic refrigerators is both intelligent and functional. A large bottle holder and a lidded container on the inside door, a vegetable bin and a storage tray provide ample space for fresh food. The CR-110 and the CR-140 additionally feature a second storage tray, two drawers and one or, respectively, two open door trays.



Separately insulated *** freezer compartment – tropical-rated

Cool cocktails with ice-cubes? Any time! All CoolMatic CR refrigerators feature a separately insulated *** freezer compartment. The thickly foamed evaporator and the extra-strong insulation ensure that a constant -18°C is maintained in the freezer compartment and the desired $+5^{\circ}\text{C}$ to $+7^{\circ}\text{C}$ in the rest of the refrigerator – even when ambient temperatures reach tropical ratings ($+43^{\circ}\text{C}$).



Patented lock: close or vent

The doors of CoolMatic CR refrigerators feature a patented locking mechanism. In cooling mode, the door is fastened top and bottom for double safety. Thus CoolMatic refrigerators will be firmly shut tight – even if the fridge contents push against the door from inside. The “vent” position keeps the door slightly open and provides ventilation when the fridge is not in use.



Installation with standard or flush-mount frame

To install a CoolMatic CR refrigerator in your galley choose the standard or flush-mount installation frame from WAECO’s range of accessories. Both options will keep your refrigerator securely in place. Using the flush-mount frame makes for a particularly elegant solution, as the refrigerator door is fitted flush with the other units rather than protruding.

Premium refrigerators for yachts and boats



CoolMatic CR-110 Chrome

CoolMatic CR-140 Chrome

CoolMatic CR-80 Chrome

CoolMatic CR-50 Chrome

CoolMatic CR-65 Chrome
(The picture shows the optional flush-mount installation frame)

WAECO CoolMatic CR Chrome

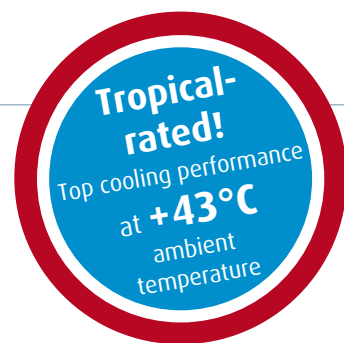
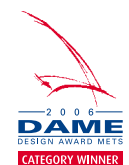

CoolMatic CR-140

CoolMatic CR-65

CoolMatic CR-110

CoolMatic CR-80

CoolMatic CR-50

CoolMatic CR / CR Chrome

- › Five models each with capacities from 48 to 136 litres and **enhanced equipment**: bottle holder, functional storage trays (CR-110 / CR-140 with drawers)
- › Ideal temperature regulation for **refrigeration and deep-freezing**
- › Separately insulated *** freezer compartment
- › **Optimal temperature distribution** due to additional evaporator integrated in the interior
- › **Unrivalled: condensation drainage via base and rear panel**. Drainage via hose in bilge and holding tank system or collection tank.
- › Double door lock (top/bottom), **variable door mounts**
- › Door lock with dual function (locking/ventilation)
- › Easy-to-change **decor panel**
- › **Tropical-rated**: equivalent to DIN EN ISO 7371
- › High-performance cooling technology: **Danfoss BDF compressor**

CoolMatic CR Chrome

- › **Installation frame in stainless steel**
- › **Front panel in brushed stainless steel**
- › **Chrome-plated door frame**

WAECO CoolMatic CR-50 / CR-50 Chrome

Premium built-in refrigerator in stainless steel or chrome finish for yachts and boats

4.24



CR-50 / CR-50 Chrome
Built-in dimensions (W x H x D)
 380 x 534 x 447 mm (without door)
With standard frame:
 384 x 536 x 447 mm
With flush-mount frame:
 406 x 536 x 495 mm

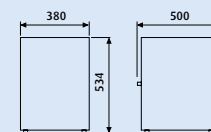

Gross capacity	approx. 48 litres including 5-litre freezer compartment
Voltage	12 / 24 volts DC
Average power consumption	approx. 40 watts
Power consumption	1.4 Ah/h at +25 °C ambient temperature, 1.7 Ah/h at +32 °C ambient temperature, both at +5 °C interior temperature and -18 °C in the freezer compartment
Insulation	CFC-free polyurethane foam
System	Fully hermetic Danfoss BD35F compressor with integrated control electronics, low-voltage protection, electronic fuse / automatic reverse pole protection, dynamically ventilated wire tube condenser, mechanical, continuously variable thermostat
Material	CR-50: Stainless steel fittings, plastic interior, plastic door frame, body with coated metal frame CR-50 Chrome: Stainless steel fittings and decor panel, plastic interior, chrome-plated door frame, body with coated metal frame
Colour	CR-50: Body: black, door frame: silver, door panel: matte-silver (brushed stainless steel finish) CR-50 Chrome: Body: black, door frame: chrome, decor panel: brushed stainless steel
Weight	19 kg
Quality features	Interior light, door with magnetic seal, variable door mounts and locks right/left, door with double lock (top/bottom) and dual function (locking/ventilation), separately insulated *** freezer compartment, additional, foamed rear-wall evaporator in the interior, easy-to-change decor panel
Test marks	CE, TÜV/GS, e-approved to 2004/104/EC (Automotive EMC Directive)

Product	Ref. No.
CoolMatic CR-50	CR-0050E
CoolMatic CR-50 Chrome	CR-0050ST
Standard installation frame for CR-50	EST-0050E
Standard installation frame for CR-50 Chrome	EST-0050ST
Flush-mount installation frame for CR-50	EFM-0050E
Flush-mount installation frame for CR-50 Chrome	EFM-0050ST
Mains adapter 110-240 V > 24 V	MPS-35

WAECO CoolMatic CR-65 / CR-65 Chrome

Premium built-in refrigerator in stainless steel or chrome finish for yachts and boats



CR-65 / CR-65 Chrome
Built-in dimensions (W x H x D)
 448 x 525 x 492 mm (without door)
With standard frame:
 452 x 527 x 492 mm
With flush-mount frame:
 474 x 527 x 540 mm

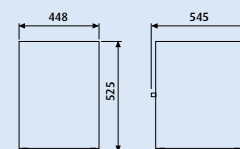

Gross capacity	approx. 64 litres including 7.2-litre freezer compartment
Voltage	12 / 24 volts DC
Average power consumption	approx. 45 watts
Power consumption	1.6 Ah/h at +25 °C ambient temperature, 1.9 Ah/h at +32 °C ambient temperature, both at +5 °C interior temperature and -18 °C in the freezer compartment
Insulation	CFC-free polyurethane foam
System	see CR-50 / CR-50 Chrome
Material	see CR-50 / CR-50 Chrome
Colour	see CR-50 / CR-50 Chrome
Weight	20 kg
Quality features	see CR-50 / CR-50 Chrome
Test marks	CE, TÜV/GS, e-approved to 2004/104/EC (Automotive EMC Directive)

Product	Ref. No.
CoolMatic CR-65	CR-0065E
CoolMatic CR-65 Chrome	CR-0065ST
Standard installation frame for CR-65	EST-0065E
Standard installation frame for CR-65 Chrome	EST-0065ST
Flush-mount installation frame for CR-65	EFM-0065E
Flush-mount installation frame for CR-65 Chrome	EFM-0065ST
Mains adapter 110-240 V > 24 V	MPS-35

- Normal cooling and *** freezer compartment
- Suitable for solar operation
- Tropical-rated (equivalent to DIN EN ISO 7371)
- Condensation drainage via the base (hose connection) or back panel (collection tank)

Separately insulated *** freezer compartment

Can be fitted in existing furnishings thanks to pre-drilled, resealable holes

Easy-to-change decor panel

Replaceable door seal

Right-hinged door as standard

Standard or flush-mount installation frame available as accessory

230-volt connection with low-priced mains adapter (p. 62 - 65)

WAECO CoolMatic CR-80 / CR-80 Chrome

Premium built-in refrigerator in stainless steel or chrome finish for yachts and boats

4.24



CR-80



CR-80 Chrome

CR-80 / CR-80 Chrome
Built-in dimensions (W x H x D)
 475 x 640 x 475 mm (without door)
With standard frame:
 479 x 642 x 475 mm
With flush-mount frame:
 501 x 642 x 523 mm

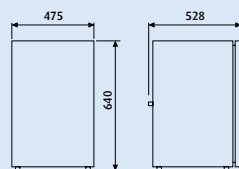

Gross capacity	approx. 80 litres including 7.9-litre freezer compartment
Voltage	12 / 24 volts DC
Average power consumption	approx. 48 watts
Power consumption	1.8 Ah/h at +25 °C ambient temperature, 2.1 Ah/h at +32 °C ambient temperature, both at +5 °C interior temperature and -18 °C in the freezer compartment
Insulation	CFC-free polyurethane foam
System	Fully hermetic Danfoss BD35F compressor with integrated control electronics, low-voltage protection, electronic fuse / automatic reverse pole protection, dynamically ventilated wire tube condenser, mechanical, continuously variable thermostat
Material	CR-80: Stainless steel fittings, plastic interior, plastic door frame, body with coated metal frame CR-80 Chrome: Stainless steel fittings and decor panel, plastic interior, chrome-plated door frame, body with coated metal frame
Colour	CR-80: Body: black, door frame: silver, door panel: matte-silver (brushed stainless steel finish) CR-80 Chrome: Body: black, door frame: chrome, decor panel: brushed stainless steel
Weight	23 kg
Quality features	Interior light, door with magnetic seal, variable door mounts and locks right / left, door with double lock (top / bottom) and dual function (locking / ventilation), separately insulated *** freezer compartment, additional, foamed rear-wall evaporator in the interior, easy-to-change decor panel
Test marks	CE, TÜV/GS, e-approved to 2004/104/EC (Automotive EMC Directive)

Product	Ref. No.
CoolMatic CR-80	CR-0080E
CoolMatic CR-80 Chrome	CR-0080ST
Standard installation frame for CR-80	EST-0080E
Standard installation frame for CR-80 Chrome	EST-0080ST
Flush-mount installation frame for CR-80	EFM-0080E
Flush-mount installation frame for CR-80 Chrome	EFM-0080ST
Mains adapter 110-240 V > 24 V	MPS-35



Normal cooling and *** freezer compartment



Suitable for solar operation



Tropical-rated (equivalent to DIN EN ISO 7371)

Condensation drainage via the base (hose connection) or back panel (collection tank)

Separately insulated *** freezer compartment

Can be fitted in existing furnishings thanks to pre-drilled, resealable holes

Easy-to-change decor panel

Replaceable door seal

Right-hinged door as standard

Standard or flush-mount installation frame available as accessory

230-volt connection with low-priced mains adapter (p. 62 - 65)

WAECO CoolMatic CR-110 / CR-110 Chrome

Premium built-in refrigerator in stainless steel or chrome finish for yachts and boats



CR-110 / CR-110 Chrome
Built-in dimensions (W x H x D)
 520 x 745 x 505 mm (without door)
With standard frame:
 524 x 747 x 505 mm
With flush-mount frame:
 546 x 747 x 553 mm

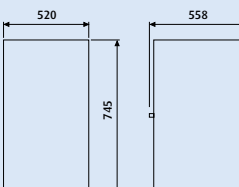

Gross capacity	approx. 108 litres including 10.2-litre freezer compartment
Voltage	12 / 24 volts DC
Average power consumption	approx. 50 watts
Power consumption	2.2 Ah/h at +25 °C ambient temperature, 2.5 Ah/h at +32 °C ambient temperature, both at +5 °C interior temperature and -18 °C in the freezer compartment
Insulation	CFC-free polyurethane foam
System	see CR-80 / CR-80 Chrome
Material	see CR-80 / CR-80 Chrome
Colour	see CR-80 / CR-80 Chrome
Weight	28 kg
Quality features	see CR-80 / CR-80 Chrome
Test marks	CE, TÜV/GS, e-approved to 2004/104/EC (Automotive EMC Directive)

Product	Ref. No.
CoolMatic CR-110	CR-0110E
CoolMatic CR-110 Chrome	CR-0110ST
Standard installation frame for CR-110	EST-0110E
Standard installation frame for CR-110 Chrome	EST-0110ST
Flush-mount installation frame for CR-110	EFM-0110E
Flush-mount installation frame for CR-110 Chrome	EFM-0110ST
Mains adapter 110-240 V > 24 V	MPS-35

WAECO CoolMatic CR-140 / CR-140 Chrome

Premium built-in refrigerator in stainless steel or chrome finish for yachts and boats

4.24



CR-140



CR-140 Chrome

CR-140 / CR-140 Chrome
Built-in dimensions (W x H x D)
 525 x 805 x 569 mm (without door)
With standard frame:
 529 x 807 x 569 mm
With flush-mount frame:
 551 x 807 x 619 mm

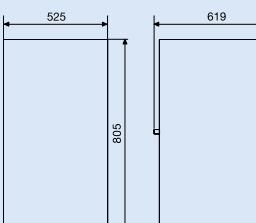

Gross capacity	approx. 136 litres including 11.5-litre freezer compartment
Voltage	12 / 24 volts DC and 100 - 240 volts AC
Average power consumption	approx. 65 watts
Power consumption	2.3 Ah/h at +25 °C ambient temperature, 2.6 Ah/h at +32 °C ambient temperature, both at +5 °C interior temperature and -18 °C in the freezer compartment
Insulation	CFC-free polyurethane foam
System	Fully hermetic Danfoss BD50F compressor with integrated control electronics, low-voltage protection, electronic fuse / automatic reverse pole protection, dynamically ventilated wire tube condenser, mechanical, continuously variable thermostat
Material	CR-140: Stainless steel fittings, plastic interior, plastic door frame, body with coated metal frame CR-140 Chrome: Stainless steel fittings and decor panel, plastic interior, chrome-plated door frame, body with coated metal frame
Colour	CR-140: Body: black, door frame: silver, door panel: matte-silver (brushed stainless steel finish) CR-140 Chrome: Body: black, door frame: chrome, decor panel: brushed stainless steel
Weight	32 kg
Quality features	Interior light, door with magnetic seal, variable door mounts and locks right / left, door with double lock (top / bottom) and dual function (locking / ventilation), separately insulated *** freezer compartment, additional, foamed rear-wall evaporator in the interior, easy-to-change decor panel
Test marks	CE, TÜV/GS, e-approved to 2004/104/EC (Automotive EMC Directive)

Condensation drainage via the base (hose connection) or back panel (collection tank)

Separately insulated *** freezer compartment

Can be fitted in existing furnishings thanks to pre-drilled, resealable holes

Easy-to-change decor panel

Replaceable door seal

Right-hinged door as standard

Standard or flush-mount installation frame available as accessory

> 136-litre capacity including 11.5-litre *** freezer compartment, separately insulated

Product	Ref. No.
CoolMatic CR-140	9105600002
CoolMatic CR-140 Chrome	9105600003
Standard installation frame for CR-140	9105900001
Standard installation frame for CR-140 Chrome	9105900002
Flush-mount installation frame for CR-140	9105900003
Flush-mount installation frame for CR-140 Chrome	9105900004



Normal refrigeration and *** freezer compartment



Suitable for solar operation



Tropical-rated (equivalent to DIN EN ISO 7371)



12 / 24 Volt DC and 100 - 240 Volt AC

Condensation drainage via the base (hose connection) or back panel (collection tank)

Separately insulated *** freezer compartment

Can be fitted in existing furnishings thanks to pre-drilled, resealable holes

Easy-to-change decor panel

Replaceable door seal

Right-hinged door as standard

Standard or flush-mount installation frame available as accessory



The "side-by-side" solution for perfectionists

Fridge / freezer combination with WAECO CoolMatic RSD-115 / RSF-115

The same outer dimensions, the same front in stainless steel, and even the same capacities (115 litres each): the **CoolMatic RSD-115** refrigerator and the **RSF-115** freezer are **an elegant duo**.

Side by side, they form a **powerful fridge / freezer** combo with a **total capacity of 230 litres**, and they can also be used separately.



WAECO CoolMatic RSD-115 / RSF-115

Compressor refrigerator or freezer with stainless steel interior and stainless steel front

4.04



RSD-115
Built-in dimensions without cooling unit (W x H x D)
With standard frame: 528 x 744 x 507 mm
With flush-mount frame: 543 x 740 x 550 mm

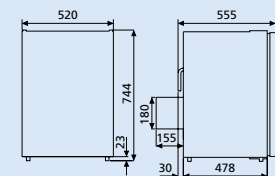

RSF-115
Built-in dimensions without cooling unit (W x H x D)
With standard frame: 528 x 744 x 507 mm
With flush-mount frame: 543 x 740 x 550 mm

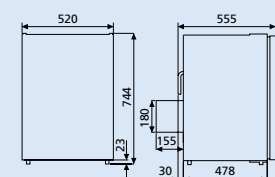

	RSD-115	RSF-115 freezer
Gross capacity	approx. 115 litres	approx. 115 litres
Voltage	12 / 24 volts DC	12 / 24 volts DC
Average power consumption	approx. 45 watts	approx. 50 watts
Average running time	30% at +20°C, 45% at +32°C ambient temperature both at +5°C interior temperature	50% at +20°C, 70% at +32°C ambient temperature both at -18°C interior temperature
Current consumption	Power input x average running time	
Temperature range	Refrigeration	***-deep-freezing
Insulation	50 mm polyurethane, CFC-free	
System	Detachable cooling unit (W 358 x H 180 x D 155 mm) with 2 m supply cord, fully hermetic Danfoss BD35F compressor with integrated control electronics, low-voltage protection for leisure or starter battery, electronic fuse/automatic reverse pole protection, dynamically ventilated fin condenser, aluminium rollbond evaporator, mechanical, continuously variable thermostat	
Material	Door frame in plastic, body with coated metal frame, door panel and interior in stainless steel	
Colour	Body and frame: black, door panel: silver (exchangeable)	
Weight	28.5 kg	
Quality features	Interior light, door with magnetic seal, variable door mounts and locks (right / left), door with double lock (top / bottom) and dual function (locking / ventilation); RSF-115: condensation drain in the stainless steel interior	
Test marks	CE, TÜV/GS, e-approved to 2006/28/EC (Automotive EMC Directive)	

Product	Ref. No.
CoolMatic RSD-115	RSD-0115E
CoolMatic RSF-115	RSF-0115E
Standard installation frame	EST-0400
Flush-mount installation frame	EFM-0400
Additional optional extra	
Mains adapter 230 V > 24 V	EPS-100W
Mains adapter 110 - 240 V > 24 V	MPS-35



RSF-115:
Deep-freezing
up to -18°C
RSD-115:
Normal refrigeration



Suitable for
solar operation

Fridge and freezer as a
"side-by-side" solution

Right-hinged door
as standard

Standard or flush-mount
installation frame
available as accessory



Ideal in confined spaces:
separate cooling unit,
can be fitted up to two
metres away from the
refrigerator



Condensation drain
in the stainless steel
interior
(RSF-115)

230-volt connection
with low-priced
mains adapters
(p. 62 - 65)



A clear overview day and night:
interior light as standard



Easy to clean and hygienic:
the stainless steel interior



Fold-up front grille
to stop loose items from sliding



CoolMatic HDC-150L

CoolMatic HDC-150FF

CoolMatic HDC-150DF

New: Favourably-priced under-cabinet solution

Ideally integrated normal refrigeration or deep freezing

Would you also like your on-board kitchenette cast from the same mould? Then it's time to get acquainted with the new refrigerator series WAECO CoolMatic HDC-150. All three units can easily be equipped with decor panels and integrated into existing furnishings.

WAECO CoolMatic HDC-150L / -150FF / -150DF: These three compressor refrigerators have the same exterior dimensions, and are ready for connection to 12 / 24 volts DC and 100 – 240 volts AC. When it comes to the interior, they vary as follows: the HDC-150FF provides 101 litre fridge capacity as well as a 17-litre froster. The HDC-150L instead provides 142 litres for normal refrigeration without froster. The HDC-150DF is a straight-up freezer with 105 litres capacity, distributed over three pull-out compartments.



Separate 17-litre freezer compartment in the HDC-150FF



Practical door trays and bottle holder



Perfectly equipped for fitting decor panels



Temperature regulation via continuously variable thermostat

WAECO CoolMatic HDC-150L

Built-in compressor refrigerator



Gross capacity	approx. 147 litres
Voltage	12 / 24 volts DC and 100-240 volts AC
Average power consumption	approx. 70 watts
Power consumption	1.2 Ah/h at +20°C ambient temperature, 2.5 Ah/h at +32°C ambient temperature, at +5°C interior temperature
Insulation	Polyurethane full-foam insulation
System	Fully hermetic Danfoss BD50F compressor with integrated control electronics, low-voltage protection, electronic fuse / automatic reverse pole protection, mechanical, continuously variable thermostat
Material	Body and doors in sheet steel, interior of impact-resistant polystyrene
Colour	Cabinet, inside door lining and interior: white
Weight	approx. 27.5 kg
Quality features	Interior light, door with magnetic seal, variable door hinges and locks (right / left)
Scope of delivery	3 safety-glass shelves, a crisper, door trays
Test marks	CE, e-approved to 2006/28/EC (Automotive EMC Directive)

WAECO CoolMatic HDC-150FF

Built-in compressor refrigerator with freezer compartment



Gross capacity	approx. 120 litres including 17-litre *** freezer compartment
Voltage	12 / 24 volts DC and 100-240 volts AC
Average power consumption	approx. 60 watts
Power consumption	1.4 Ah/h at +20°C ambient temperature, 2.1 Ah/h at +32°C ambient temperature, both at +5°C interior temperature and -18°C in the freezer compartment
Weight	approx. 30.5 kg
Scope of delivery	2 safety-glass shelves, a crisper, door trays
Other specifications as for CoolMatic HDC-150L	

WAECO CoolMatic HDC-150DF

Built-in compressor freezer

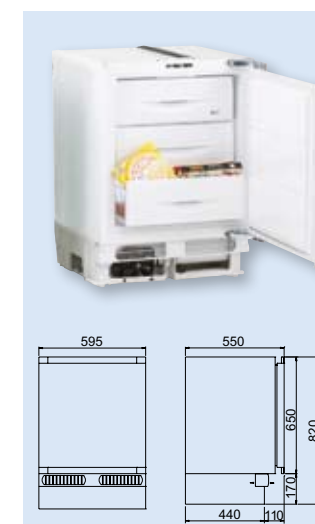

Gross capacity	approx. 105 litres
Voltage	12 / 24 volts DC and 100-240 volts AC
Average power consumption	approx. 70 watts
Power consumption	1.6 Ah/h at +20°C ambient temperature, 2.1 Ah/h at +32°C ambient temperature, both at -18°C interior temperature
Weight	approx. 31 kg
Quality features	Door with magnetic seal, variable door hinges and locks (right / left)
Scope of delivery	3 pull-out freezer compartments
Other specifications as for CoolMatic HDC-150L	

Product	Ref. No.
CoolMatic HDC-150L	9105600020
CoolMatic HDC-150FF	9105600019
CoolMatic HDC-150DF	9105600018

4.06

NEW



HDC-150L:
Normal refrigeration
HDC-150FF:
Normal refrigeration and deep-freezing up to -18°C
HDC-150DF:
Deep-freezing up to -18°C



Suitable for solar operation



12 / 24 volts DC and 100 – 240 volts AC

Ideal for under cabinets or free-standing installation



CoolMatic HDC-190

CoolMatic HDC-220

CoolMatic HDC-270

Jumbo-size cooling

Compressor refrigerators for commercial shipping and large yachts

Home-like comfort: plenty of space for fresh food, separate doors for the refrigerator and freezer. Featuring a perfectly organised interior with multi-boxes and door trays. The new WAECO CoolMatic HDC-270 has three pull-out drawers alone for frozen foods. The snow-white refrigerator/freezer combinations have been designed inside out for mobile use and offer a fantastic price/performance ratio.



Freezer compartments divided by shelf racks (HDC-190/-220)



Large transparent crisper drawers for fruit and vegetables



Interior light as standard and continuously variable thermostat

WAECO CoolMatic HDC-190 / HDC-220 / HDC-270

Jumbo-size compressor refrigerators

4.06

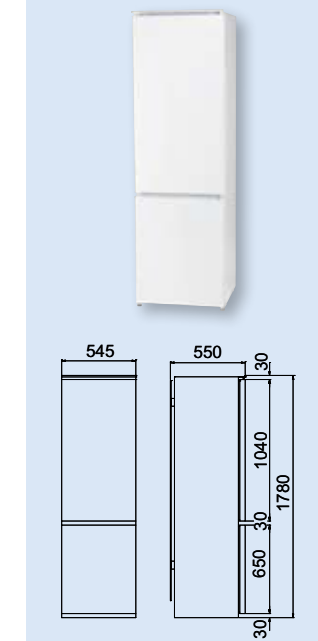
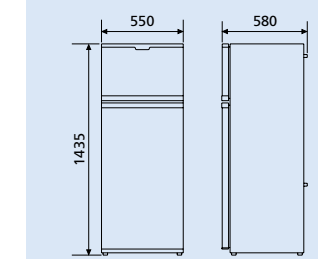
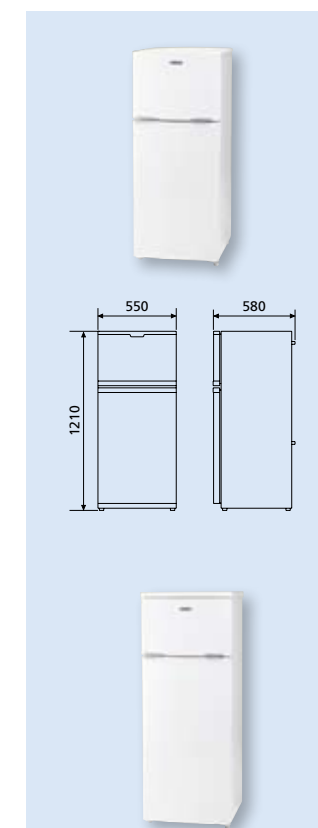

HDC-190	
Gross capacity	approx. 165 litres including 40-litre *** freezer compartment
Voltage	12 / 24 volts DC
Average power consumption	approx. 75 watts
Power consumption	1.5 Ah/h at +20°C ambient temperature, 2.1 Ah/h at +32°C ambient temperature, both at +5°C interior temperature and -18°C in the freezer compartment
Insulation	Polyurethane full-foam insulation
System	Fully hermetic Danfoss BD50F compressor with integrated control electronics, low-voltage protection, electronic fuse / automatic reverse pole protection, mechanical, continuously variable thermostat
Material	Body and doors in sheet steel, interior of impact-resistant polystyrene
Colour	Cabinet, inside door lining and interior: white
Weight	33 kg
Quality features	Interior light, door with magnetic seal, variable door hinges and locks (right / left), two separate doors
Scope of delivery	3 safety glass shelves, two adjustable in height, a transparent crisper, shelf rack in froster compartment, door trays
Test marks	CE, e-approved to 2006/28/EC (Automotive EMC Directive)

HDC-220	
Gross capacity	approx. 218 litres including 41-litre *** freezer compartment
Average power consumption	approx. 80 watts
Power consumption	1.8 Ah/h at +20°C ambient temperature, 3.2 Ah/h at +32°C ambient temperature, both at +5°C interior temperature and -18°C in the freezer compartment
Weight	42 kg
Quality features	Interior light, door with magnetic seal, variable door hinges and locks (right / left), two separate doors
Scope of delivery	3 safety glass shelves, two adjustable in height, a transparent crisper, shelf rack in froster compartment, door trays
Other specifications as for CoolMatic HDC-190	

HDC-270	
Gross capacity	approx. 281 litres including 61-litre *** freezer compartment
Voltage	12 / 24 volts DC and 110 - 240 volts AC
Average power consumption	approx. 120 watts
Power consumption	4.1 Ah/h at +20°C ambient temperature, 4.6 Ah/h at +32°C ambient temperature, both at +5°C interior temperature and -18°C in the freezer compartment
System	Fully hermetic Danfoss BD80F compressor with integrated control electronics, low-voltage protection, electronic fuse / automatic reverse pole protection, mechanical, continuously variable thermostat
Weight	50 kg
Quality features	Interior light, door with magnetic seal, variable door hinges and locks (right / left), two separate doors
Scope of delivery	4 safety glass shelves, three adjustable in height, a transparent crisper, door trays, three drawers for frozen food
Other specifications as for CoolMatic HDC-190	

Product	Ref. No.
CoolMatic HDC-190	9105600013
CoolMatic HDC-220	9105600014
CoolMatic HDC-270	9105600021
Optional extra (HDC-190 / -220) Mains adapter 110-240 V > 24 V	MPS-50

NEW



Deep-freezing up to -18°C



Suitable for solar operation

HDC-190 / -220 Large freezer compartments with separate door

Transport lock

230-volt connection with low-priced mains adapter (p. 62 - 65)

HDC-270 Fridge / freezer combination



12 / 24 volts DC and 110-240 volts AC