



Light and air for living

Dometic SEITZ systems for recreational vehicles

When you're free and out in the open and you want to enjoy fresh air with perfect light conditions, then you can rely on Dometic product brands. Over 70% of all European motorhome manufacturers have long been doing that and use our window systems. That's because they offer a high degree of protection, convenience and quality. Do you want that for your recreational vehicle too? No problem, just install and go! A huge range awaits you: hinged and sliding windows, fly screens and roller blinds in all sizes and models, as well as an ever expanding range of accessories.

Windows and Hekis

Quality from the market leader: manufacturers of recreational vehicles all over the world put their trust in window solutions from Dometic due to their outstanding functionality, perfect workmanship and easy handling. The variety of products leaves nothing to be desired – ranging from innovative roof windows to proven "Hekis", to models with or without frames and sliding or hinged windows.

Dometic SEITZ Pages 184 – 191



Roller blinds

Privacy away from prying eyes. Wide range of products in proven quality: from heat-insulating blackout screens for driver cabins, to combined cassette roller blinds with fly screens, to normal spring roller blinds. For windows and roof openings in all standard sizes.

Dometic SEITZ Pages 192 – 196



Optional extras

We pay careful attention to detail with Dometic SEITZ, so that you always feel comfortable in your recreational vehicle. Easy-to-mount fly screen solutions for entry doors are also available, as well as safety nets for bunk-beds and a pull-out clothes drier.

Cleaning and polishing agents for acrylic windows, as well as service hatches for motorhomes and caravans complete the Dometic SEITZ accessory range.

Dometic SEITZ

Pages 197 – 199



Innovation



AirQuad – the new patented ventilation system

Power for ventilation or air conditioning systems is precious and costly, but the wind blows free of charge. Dometic AirQuad captures more wind than any other roof hood, creates a pleasant flow of fresh air and directs it into the vehicle. The direction of the wind is irrelevant for this new model. Its success lies in the new type of

patented flow guiding element, which is built into a glass dome. This is adjustable by height so you can regulate the air intake. AirQuad lets you enjoy active ventilation and passive cooling with absolutely no energy costs. An effective alternative to hinged roof windows and a useful addition to your air conditioning system.

- Inner frame with blackout and fly screen, variably adjustable
- Easy to use with handles
- Five positions [to the front, rear, left, right or up]
- Maximum adjustable height: 80 mm
- Forced ventilation
- Double acrylic glazing
- Designed for standard roof sizes of 400 mm x 400 mm
- For roof thicknesses of 23 to 60 mm

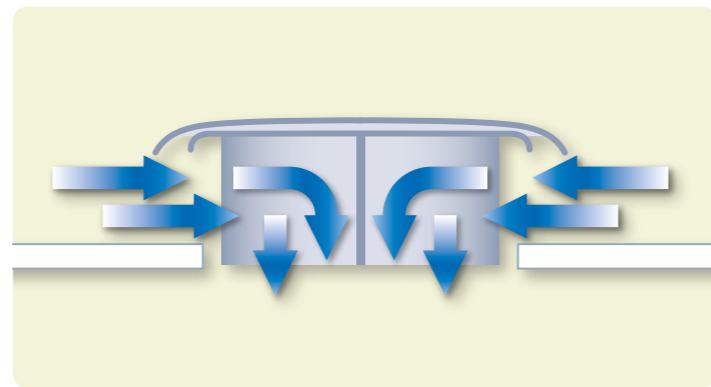

Highly-efficient ventilation system without power

The air outside is "gathered" from all sides and directed into the vehicle via the patented air flow guiding element. This creates a pleasant, cool indirect air flow. The amount of air can be regulated by adjusting the height of the glass dome.

Dometic AirQuad Roof windows with passive ventilation for motorhomes

3.42



Model	AirQuad
Operation	Handles
Glazing PMMA – double-glazing	•
Positions	5
Weight [kg]	3.4
Blackout screen	Single pleating
Fly screen	Single pleating
Forced ventilation	•
Standard roof thickness [mm]	23–42 / 43–60
Possible roof thickness [mm]	23–60*
Frame material	ASA
Frame colour	RAL 9001
Assembly size [mm]	500 x 500
Space [mm]	400 x 400

* Requires screw bosses to be shortened

NEW

- Patented air flow guiding element
- Double acrylic glazing
- Easy to use
- No mechanical background noise

Product	Ref. No.
Dometic AirQuad, 23–42 mm	9104100319
Dometic AirQuad, 43–60 mm	9104100320



Square design, suitable for standard roof sizes



Easy to use with two handles



Variably adjustable: the blackout roller blind ...

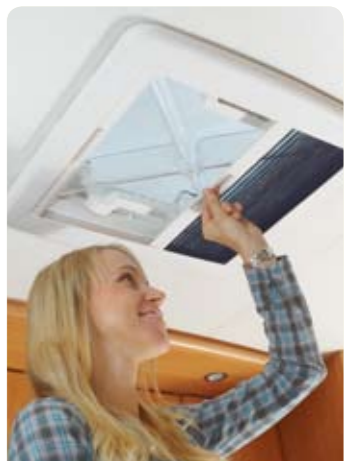

... and the fly screen

Top class travelling comfort – the Heki range

So that you can enjoy your holiday in an ideal atmosphere in comfort and safety, Dometic SEITZ has designed a huge range of tilting roof windows [“Heki” for short] for all types of caravan or motorhome. You can choose between the mini Heki, midi Heki and Hekis – with electronic remote control, hand lever or crank. Heki roller blinds can be made from Duette honeycomb fabric, roller blind material or just single pleated material.

Heki 4plus – the convenient roof system

Heki 4plus offers you absolute convenience with a useful remote control. The roof closes automatically when it's raining and has a pleated fly screen made of black gauze, as well as two built in lamps for dimmed lighting. Fly screen and blackout roller blind are fitted from the side and allow you to adjust as you require.

- Rain sensor and integrated energy-saving lamps
- Perfect sun protection with Duette honeycomb roller blinds
- Control light indicates when correctly locked
- Sturdy locking system
- Maximum opening angle: 70°
- Double acrylic glazing
- Weatherproof ASA frames
- Remote control



Heki 4plus is equipped with a rain sensor

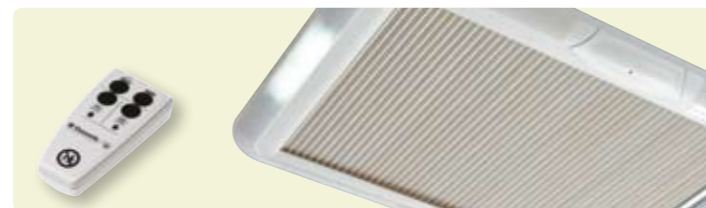

Extremely convenient: with remote control and lighting

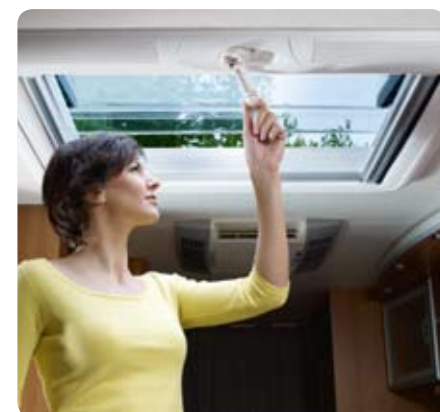

Heki 3plus – convenient model with hand crank, for motorhomes and caravans

Offers the same convenience as the Heki 4plus, but with a hand crank system and without the rain sensor

- Integrated lighting
- Perfect sun protection with double pleated Duette honeycomb roller blinds
- Sturdy locking system
- Maximum opening angle: 70°
- Double acrylic glazing
- Weatherproof ASA frames
- For roof thicknesses of 25 to 60 mm



Heki 2 deluxe – exclusive roof window for caravans

- Inner frame with blackout roller blind and fly screen, [variably adjustable together]
- Integrated lighting
- High degree of insulation with double-pleated Duette honeycomb roller blinds
- Forced ventilation
- Maximum opening angle: 55°
- Pneumatic springs for convenient roof adjustment
- Double acrylic glazing
- For roof thicknesses of 25 to 60 mm



Heki 2 – for caravans

- Inner frame with blackout roller blind and fly screen, [variably adjustable together]
- Forced ventilation
- Maximum opening angle: 55°
- Pneumatic springs for convenient roof adjustment
- Double acrylic glazing
- For roof thicknesses of 25 to 60 mm



Heki 1 – for motorhomes

- Inner frame with blackout roller blind and fly screen, [variably adjustable together]
- Sturdy locking system
- Maximum opening angle: 70°
- Five positions for optimum ventilation adjustment
- Polyurethane frames with high insulation quality
- Double acrylic glazing
- For roof thicknesses of 27 to 60 mm

Dometic SEITZ Hekis

3.42

Model	Heki 1	Heki 2	Heki 2 deluxe	Heki 3plus	Heki 4plus
Motorhomes	●	–	–	●	●
Caravans	●	●	●	●	●
Operation	Crank/handle	Lever	Lever	Crank	Remote control
PMMA glazing	–	–	–	–	–
– Single-glazing	●	●	●	●	●
– Double-glazing	–	–	–	–	–
Positions	5/variable	3	3	variable	variable
Max. opening angle	70°	55°	55°	70°	70°
12 V lamps	–	–	4 x 5 Watt	2 x 8 Watt	2 x 8 Watt
Weight [kg]	22.0	11.0	11.0	15.0	15.5
Rain sensor	–	–	–	–	●
Blackout screen	Roller blind system	Roller blind system	Duette	Duette	Duette
Fly screen	–	–	–	●	●
– Single pleats	●	●	●	–	–
– Roller blind system	–	–	–	–	–
Forced ventilation	–	●	●	–	–
Standard roof thickness [mm]	27	25–32	25–32	25–32	25–32
Possible roof thickness [mm]	28–60*	25–60**	25–60**	25–60**	25–60**
Frame material	Polyurethane foam	ASA	ASA	ASA	ASA
Frame colour	RAL 9001	RAL 9001	RAL 9001	RAL 9001	RAL 9001
External space requirement [mm]	1100 x 820	1080 x 790	1080 x 790	1080 x 790	1080 x 790
Space size [mm]	960 x 655	960 x 655	960 x 655	960 x 655	960 x 655

* Requires inner frame to be shortened ** Requires additional assembly set

Product	Ref. No.
Heki 1	9104100112
Heki 2	9104100235
Heki 2 deluxe	9104100240
Heki 3plus	9104100292
Heki 4plus	9104100294
Assembly set Heki 2–4, WS 32–39 mm	9104100245
Assembly set Heki 2–4, WS 39–46 mm	9104100246
Assembly set Heki 2–4, WS 46–53 mm	9104100247
Assembly set Heki 2–4, WS 53–60 mm	9104100248
Optional extras	
Inner frame Heki 2 deluxe	9104100241
Spoiler Heki 1–4, 800 mm	9104100236
Spoiler Heki 1–4, 1100 mm	9104100237



Midi Heki – for motorhomes and caravans

The large roof opening [700 x 500 mm] allows optimum ventilation and light conditions. Easy to use with lever, crank or electric system.

- Inner frame with blackout and fly screen, [can be adjusted separately]
- Available with or without forced ventilation
- Maximum opening angle: 45° [Lever model], 60° [crank and electric models]
- Three positions [Lever model]; variable opening [crank and electric models]
- Double acrylic glazing
- For roof thicknesses of 25 to 60 mm

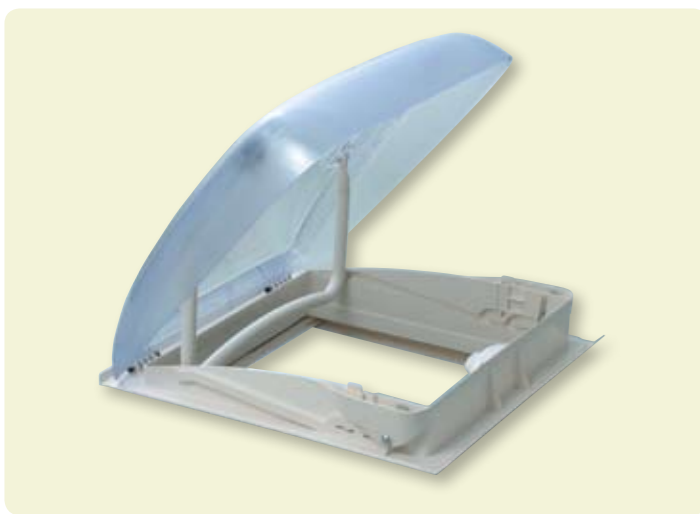

Mini Hekiplus – for motorhomes and caravans

This small roof window fits neatly into the roof opening for the standard size of 400 x 400 mm and provides maximum light.

- Inner frame with blackout and fly screen, [can be adjusted separately]
- The glass dome is easy to adjust using the handy crank system
- Available with or without forced ventilation
- Maximum opening angle: approx. 50°
- Three positions: fully open, ventilation position, bad weather position
- Double acrylic glazing
- For roof thicknesses of 25 to 60 mm



Mini Heki S – for caravans

Small roof windows, great effect: Mini Heki S are designed for standard roof openings [400 x 400 mm].

- Inner frame with blackout and fly screen, [can be adjusted separately]
- Easy to use with handles
- Forced ventilation
- Maximum adjustable height: approx. 80 mm
- Five positions
- Single acrylic glazing
- For roof thicknesses of 23 to 60 mm

The midi Heki is available as a lever, hand crank or electric model



Fly screen frames for Midi Heki

Leaves and dirt no longer get into the vehicle and interfere with the roof window operation or the roller blind system. The fly screen can easily be retrofitted for any Midi Heki with crank or electric operation and removed again for cleaning purposes. Extremely sturdy model with aluminium profiles and UV resistant polyester material.

Dometic SEITZ Hekis

3.42

Model	Midi Heki	Mini Hekiplus	Mini Heki S
Motorhomes	•	•	-
Caravans	•	•	•
Operation	Lever/crank/electric	Lever	Handle
PMMA glazing			
- Single-glazing	-	-	•
- Double-glazing	•	•	-
Positions	3/variable/variable	3	5
Max. opening angle	45°/60°/60°	50°	-
12 V lamps	-	-	-
Weight, kg	8.0/8.5/9.0	3.3	2.9
Rain sensor	-	-	-
Blackout screen	Single pleating	Single pleating	Single pleating
Fly screen			
- Single pleats	•	•	•
- Roller blind system	-	-	-
Forced ventilation	Possible	Possible	•
Standard roof thickness [mm]	30-34	25-42/43-60	22-42/43-60
Possible roof thickness [mm]	25-29/35-60*	25-60**	23-60**
Frame material	ASA	ASA	ASA
Frame colour	RAL 9001	RAL 9001	RAL 9001
External space requirement [mm]	880 x 650	550 x 510	500 x 500
Space size [mm]	700 x 500	400 x 400	400 x 400

* Requires additional assembly set ** Requires screw bosses to be shortened

Product	Ref. No.
Midi Heki, lever model, with forced ventilation	9104100253
Midi Heki, lever model, without forced ventilation	9104100254
Midi Heki, crank model, with forced ventilation	9104100255
Midi Heki, crank model, without forced ventilation	9104100256
Midi Heki, electric model, with forced ventilation	9104100257
Midi Heki, electric model, without forced ventilation	9104100258
Mini Hekiplus, without forced ventilation, 25-42 mm	9104100249
Mini Hekiplus, without forced ventilation, 43-60 mm	9104100250
Mini Hekiplus, with forced ventilation, 25-42 mm	9104100251
Mini Hekiplus, with forced ventilation, 43-60 mm	9104100252
Mini Heki S, 23-42 mm	9104100289
Mini Heki S, 43-60 mm	9104100290
Midi Heki assembly set, 25-29 mm	9104100261
Midi Heki assembly set, 30-34 mm	9104100262
Midi Heki assembly set, 35-42 mm	9104100263
Midi Heki assembly set, 43-52 mm	9104100264
Midi Heki assembly set, 53-60 mm	9104100265
Optional extras	
Midi Heki fly screen frame	9104100259
Mini Heki spoiler	9104100260
Midi Heki spoiler, 800 mm	9104100236

Individual window solutions for any vehicle

S4 series: tailor-made by the market leader

Looking for a quality framed window solution for your motorhome or caravan? Then we recommend the hinged and sliding windows from the Dometic SEITZ S4 series. They come with excellent references. After all, they were designed by the international market leader for polyurethane and aluminium window systems and have been installed countless times already. They stand for high functionality, first-rate quality, easy operation and are available in any conceivable size. The window you want is guaranteed to be there!



The benefits of S4 windows

- Convenient one-hand operation: fly screen and blackout roller blinds can be clipped together and adjusted with one hand at the same time.
- Easy handling in different positions
- High degree of insulation: blackout roller blinds with aluminium coating
- Quick and easy installation
- Robust quality with double acrylic glazing
- Highly versatile: for wall thicknesses of 26–41 mm [fitted by shortening the inner frame]
- Sliding window with left or right models
- Large range of sizes



S4 hinged windows with polyurethane frames

S4 hinged window – the complete system

Proven millions of times: complete windows for motorhomes and caravans with telescopic hinges for convenient ventilation and built in blackout roller blinds and fly screens. This outstanding insulation corresponds to construction standards for homes. Security locking system prevents windows from being opened on the outside.



S4 sliding windows with polyurethane frames

S4 sliding window – first choice

The classic model with acrylic glass panes and locking system. The front pane [from the driver's perspective] is adjustable, the rear pane is fixed. External and internal frames are screwed together from the inside and provide durable and effective insulation.

Dometic SEITZ S4 windows Polyurethane window frames

3.42

Size W x H	Overall size W x H	Opening size W x H	Hinged window size W x H	Weight kg	Hinged window	Sliding window left	Sliding window right
					Ref. No.	Ref. No.	Ref. No.
350 x 500	393 x 531	343 x 498	254 x 354	4.1	9104100001	–	–
500 x 300	544 x 330	499 x 298	404 x 154	4.0	9104100002	–	–
500 x 350	544 x 380	500 x 348	404 x 204	4.2	9104100003	–	–
500 x 450	544 x 480	500 x 448	404 x 304	5.0	9104100004	9104100141	9104100142
500 x 500	544 x 531	499 x 499	404 x 354	5.7	9104100005	–	–
500 x 600	544 x 631	499 x 599	404 x 454	6.0	9104100006	–	–
550 x 550	594 x 581	549 x 549	454 x 404	5.7	9104100007	–	–
550 x 580	594 x 611	548 x 578	454 x 434	6.3	9104100008	9104100143	9104100144
550 x 600	594 x 631	549 x 599	454 x 454	6.1	9104100009	–	–
600 x 350	644 x 380	599 x 348	504 x 204	5.0	–	9104100145	9104100146
600 x 500	644 x 531	599 x 498	504 x 354	6.1	9104100010	9104100147	9104100148
600 x 600	644 x 631	599 x 599	504 x 454	7.0	9104100011	9104100149	9104100150
650 x 300	695 x 330	650 x 298	554 x 154	4.8	9104100012	–	–
700 x 300	745 x 330	700 x 298	604 x 154	5.3	9104100013	9104100151	9104100152
700 x 350	745 x 380	699 x 347	604 x 204	5.7	9104100014	–	–
700 x 400	745 x 430	702 x 398	604 x 254	6.1	9104100015	9104100153	9104100154
700 x 450	745 x 481	702 x 448	604 x 304	6.5	9104100016	9104100155	9104100156
700 x 500	745 x 531	700 x 498	604 x 354	7.0	9104100017	–	–
700 x 550	745 x 581	700 x 549	604 x 404	7.4	9104100018	9104100157	9104100158
700 x 600	745 x 631	702 x 599	604 x 454	7.7	9104100019	9104100159	9104100160
750 x 400	797 x 430	750 x 398	654 x 254	6.4	9104100020	9104100161	9104100162
750 x 450	797 x 481	749 x 447	654 x 304	6.6	9104100021	–	–
750 x 600	797 x 431	750 x 599	654 x 454	8.2	9104100022	9104100163	9104100164
800 x 350	846 x 380	800 x 347	704 x 204	6.6	9104100023	9104100165	9104100166
800 x 450	846 x 481	801 x 450	704 x 304	7.1	9104100024	9104100167	9104100168
900 x 300	948 x 330	902 x 298	804 x 154	6.6	9104100025	9104100169	9104100170
900 x 400	948 x 430	902 x 398	804 x 254	7.5	9104100026	9104100171	9104100172
900 x 450	948 x 481	902 x 448	804 x 304	8.0	9104100027	9104100173	9104100174
900 x 500	948 x 531	902 x 499	804 x 354	8.4	9104100028	9104100175	9104100176
900 x 550	948 x 581	902 x 549	804 x 404	8.6	9104100029	9104100177	9104100178
900 x 600	948 x 631	902 x 599	804 x 454	9.2	9104100030	9104100179	9104100180
1000 x 450	1048 x 481	1002 x 448	904 x 304	8.6	9104100031	–	–
1000 x 500	1048 x 531	1002 x 499	904 x 354	9.3	9104100032	9104100181	9104100182
1000 x 550	1048 x 581	1002 x 549	904 x 404	10.0	9104100033	9104100183	9104100184
1000 x 600	1048 x 631	1002 x 599	904 x 454	11.0	9104100034	9104100185	9104100186
1000 x 800	1048 x 832	1002 x 800	904 x 654	12.0	9104100035	–	–
1100 x 450	1148 x 481	1103 x 448	1004 x 304	9.9	9104100036	9104100187	9104100188
1100 x 550	1148 x 581	1102 x 549	1004 x 404	10.1	9104100037	–	–
1100 x 700	1148 x 733	1103 x 699	1004 x 554	11.9	9104100038	–	–
1200 x 300	1248 x 330	1201 x 297	1104 x 154	8.2	9104100039	–	–
1200 x 350	1249 x 380	1202 x 347	1104 x 204	8.8	9104100040	–	–
1200 x 500	1249 x 531	1203 x 500	1104 x 354	10.5	9104100041	–	–
1200 x 600	1249 x 631	1201 x 599	1104 x 454	12.5	9104100042	9104100189	9104100190
1200 x 700	1249 x 733	1201 x 699	1104 x 554	13.1	9104100043	–	–
1200 x 800	1249 x 832	1203 x 800	1104 x 654	13.8	9104100044	–	–
1300 x 550	1343 x 581	1298 x 549	1204 x 404	13.6	9104100045	9104100191	9104100192
1300 x 600	1343 x 631	1297 x 599	1204 x 454	14.2	9104100046	9104100193	9104100194
1450 x 550	1500 x 581	1453 x 549	1354 x 404	13.6	9104100047	–	–
1450 x 600	1500 x 631	1454 x 599	1354 x 454	14.9	9104100048	9104100195	9104100196
1450 x 700	1500 x 733	1452 x 699	1354 x 554	15.7	9104100049	–	–
1600 x 550	1650 x 581	1602 x 549	1504 x 404	15.6	9104100050	–	–
1600 x 600	1650 x 631	1602 x 599	1504 x 454	16.2	9104100051	–	–

Note: All windows have a flanging radius of R 12. All measurements are in millimetres. Changes and errors reserved.



Roller blinds – perfect screens



Dometic SEITZ blackout system for driver cabins

Screening and heat insulation perfectly combined – and assembled in a flash: Dometic SEITZ blackout systems for driver's cabins are available as faltstore from double-pleated Duette honeycomb fabric or as a front wind-screen roller blind for the Fiat Ducato 250 [07/2006 and later models]. The double-pleated Duette honeycomb fabric is particularly robust, stays in perfect shape and provides excellent insulation. The aluminium coating effectively reduces the interior temperature during the day and improves insulation from the cold at night.

- Quick and easy to assemble, without covering the ventilation slots
- Absorbs up to 99% ultra-violet rays
- High degree of insulation from heat and cold (due to internal aluminium-laminated honeycomb system)
- Variably adjustable
- High resistance compared to single pleated material

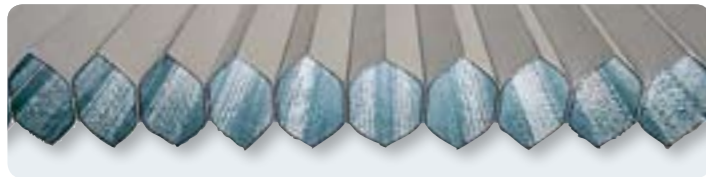

Double pleated Duette honeycomb fabric

Dometic SEITZ blackout system

3.42

For the Fiat Ducato 250 model and the same design from Peugeot Boxer and Citroën Jumper [without roof section]

Product	Ref. No.
For front windscreen, pleated [left-hand drive model], grey	9104100266
For front windscreen, pleated [right-hand drive model], grey	9104100267
For side windows, pleated [left/right], grey	9104100268



Dometic SEITZ front windscreen roller blinds

- For the Fiat Ducato 250 front windscreen and the same design from Peugeot Boxer, Citroën Jumper, as well as Fiat Ducato 230 and 244 models
- Screening and insulation due to an aluminium coating on the exterior
- Powder-coated cassette with roller blind
- Dashboard ventilation is not obstructed
- Available for left and right-hand models[250 model]

Dometic SEITZ front windscreen roller blinds

3.42

Product	Ref. No.
Fiat Ducato 250 model and the same design from Peugeot Boxer, Citroën Jumper [without roof] left-hand drive	9104100269
right-hand drive	9104100270
Fiat Ducato 230 model [from 1994 and later], Fiat Ducato 244 model [2002 and later] beige [left-hand drive]	9104100233
grey [left-hand drive]	9104100234



Mini-double cassette roller blind 1302

Intelligent design for perfect comfort when you're on the road: fly screen and blackout roller blind can be joined together and then adjusted at the same time. Alternatively, the roller blind can be used separately in three positions. The special cassette design provides additional ventilation: it allows the air to circulate between the glass pane and the roller blind when it is pulled down to ensure your privacy and protection from insects at the same time.

- Night-time security: when the roller blind is pulled down, a gap is left to allow the air to circulate through the fly screen
- Easy assembly: the fly screen at the top, the blackout screen at the bottom of the window
- Excellent insulation with aluminium coating
- Highly versatile: vertical guide rails can be shortened
- Also available for roof windows

Dometic SEITZ Mini-double cassette roller blind/roof window roller blind 1302 3.42

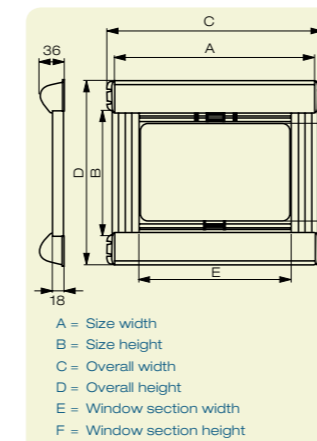

Standard size for Mini double cassette roller blind

Size A [mm]	Size B [mm]	Size C [mm]	Size D [mm]	Size E [mm]	Size F [mm]	Weight [kg]
630	700	658	790	580	650	1.30
680	700	708	790	630	650	1.35
730	700	758	790	680	650	1.41
780	700	808	790	730	650	1.47
830	700	858	790	780	650	1.53
930	700	958	790	880	650	1.65
1030	700	1058	790	980	650	1.77
1130	700	1158	790	1080	650	1.89
1230	700	1258	790	1180	650	2.00
1330	750	1358	840	1280	700	2.15
1430	750	1458	840	1380	700	2.27
1480	750	1508	840	1430	700	2.33
1530	750	1558	840	1480	700	2.39

Special size for roof opening

480	500	508	590	430	450	0.96
540	500	568	590	490	450	1.09
580	600	608	690	530	550	1.19

Product	Ref. No.	Product	Ref. No.
Mini-double cassette roller blind 1302, grey-white		Mini-double cassette roller blind 1302, pearl white	
630 x 700 mm	9104100052	630 x 700 mm	9104100065
680 x 700 mm	9104100053	680 x 700 mm	9104100066
730 x 700 mm	9104100054	730 x 700 mm	9104100067
780 x 700 mm	9104100055	780 x 700 mm	9104100068
830 x 700 mm	9104100056	830 x 700 mm	9104100069
930 x 700 mm	9104100057	930 x 700 mm	9104100070
1030 x 700 mm	9104100058	1030 x 700 mm	9104100071
1130 x 700 mm	9104100059	1130 x 700 mm	9104100072
1230 x 700 mm	9104100060	1230 x 700 mm	9104100073
1330 x 750 mm	9104100061	1330 x 750 mm	9104100074
1430 x 750 mm	9104100062	1430 x 750 mm	9104100075
1480 x 750 mm	9104100063	1480 x 750 mm	9104100076
1530 x 750 mm	9104100064	1530 x 750 mm	9104100077
Roof roller blind, grey white		Roof roller blind, pearl white	
480 x 500 mm	9104100078	480 x 500 mm	9104100081
540 x 500 mm	9104100079	540 x 500 mm	9104100082
580 x 600 mm	9104100080	580 x 600 mm	9104100083



Combination cassette roller blind 38

This product combines a fly screen and a roller blind all in one system. Slots in the cassette provide additional ventilation: they allow the air to circulate between the window and the roller blind when it is pulled down. The roller blind has an aluminium coating on the exterior to maximise insulation. The guide rails at the side can be shortened as required. Blackout roller blind and fly screen can also be used separately.

- Easy to use with one hand and for fixing in a variety of positions
- Blackout roller blinds and fly screen combined, variably adjustable



Rastrollo 2000

Designed for installing above the window, this roller blind is the perfect solution for windows without frames. It is fitted with a fly screen and a shade for sun protection – both of which can be adjusted in a variety of positions. Integrated slots provide ample ventilation, even when the roller blind is pulled down.

- Space-saving assembly above the window
- Excellent insulation with aluminium coating
- Highly versatile: vertical guide rails can be shortened
- Highly-effective insect protection

Dometic SEITZ combination cassette roller blind 38

3.42

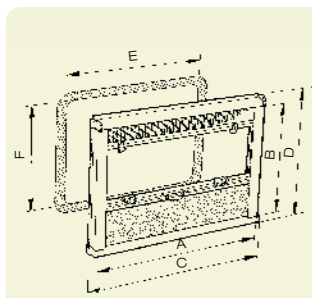

A = Size width
B = Size height
C = Overall width
D = Overall height
E = Window section width
F = Window section height

Standard size

Size A [mm]	Size B [mm]	Size C [mm]	Size D [mm]	Size E [mm]	Size F [mm]	Weight [kg]
630	700	656	795	580	650	1.95
680	700	706	798	630	650	2.05
730	700	756	795	680	650	2.12
780	700	806	795	730	650	2.21
830	700	856	795	780	650	2.29
930	700	956	795	880	650	2.46
1030	700	1056	795	980	650	2.63
1130	700	1156	795	1080	650	2.81
1230	700	1256	795	1180	650	2.98
1330	800	1356	895	1280	750	3.53
1430	800	1456	895	1380	750	3.72
1480	800	1506	895	1430	750	3.82
1530	800	1556	895	1480	750	3.91
1630	800	1656	895	1580	750	4.09
1730	800	1756	895	1680	750	4.29

Product	Ref. No.	Product	Ref. No.
Combination cartridge roller blind 38, beige		Combination cartridge roller blind 38, grey	
630 x 700 mm	9104100084	630 x 700 mm	9104100098
680 x 700 mm	9104100085	680 x 700 mm	9104100099
730 x 700 mm	9104100086	730 x 700 mm	9104100100
780 x 700 mm	9104100087	780 x 700 mm	9104100101
830 x 700 mm	9104100088	830 x 700 mm	9104100102
930 x 700 mm	9104100089	930 x 700 mm	9104100103
1030 x 700 mm	9104100090	1030 x 700 mm	9104100104
1130 x 700 mm	9104100091	1130 x 700 mm	9104100105
1230 x 700 mm	9104100092	1230 x 700 mm	9104100106
1330 x 800 mm	9104100093	1330 x 800 mm	9104100107
1430 x 800 mm	9104100094	1430 x 800 mm	9104100108
1480 x 800 mm	9104100295	1480 x 800 mm	9104106411
1530 x 800 mm	9104100095	1530 x 800 mm	9104100109
1630 x 800 mm	9104100096	1630 x 800 mm	9104100110
1730 x 800 mm	9104100097	1730 x 800 mm	9104100111

Dometic SEITZ Rastrollo 2000

3.42

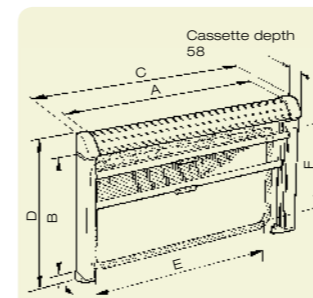

A = Size width
B = Size height
C = Overall width
D = Overall height
E = Window section width
F = Window section height

Standard size

Size A [mm]	Size B [mm]	Size C [mm]	Size D [mm]	Size E [mm]	Size F [mm]	Weight [kg]
630	700	670	794	600	650	1.52
680	700	720	794	650	650	1.57
730	700	770	794	700	650	1.63
780	700	820	794	750	650	1.68
830	700	870	794	800	650	1.74
930	700	970	794	900	650	1.85
1030	700	1070	794	1000	650	1.96
1130	700	1170	794	1100	650	2.06
1230	700	1270	794	1200	650	2.17
1330	800	1370	894	1300	750	2.37
1430	800	1470	894	1400	750	2.48
1480	800	1520	894	1500	750	2.53
1530	800	1570	894	1500	750	2.59
1580	800	1620	894	1550	750	2.60
1630	800	1670	894	1600	750	2.70
1730	800	1770	894	1700	750	2.81
1830	800	1870	894	1800	750	2.92
1930	800	1970	894	1900	750	3.02

Product	Ref. No.	Product	Ref. No.
Rastrollo 2000, pearl white		Rastrollo 2000, grey white	
630 x 700 mm	9104100113	630 x 700 mm	9104100127
680 x 700 mm	9104100114	680 x 700 mm	9104100128
730 x 700 mm	9104100115	730 x 700 mm	9104100129
780 x 700 mm	9104100116	780 x 700 mm	9104100130
830 x 700 mm	9104100117	830 x 700 mm	9104100131
930 x 700 mm	9104100118	930 x 700 mm	9104100132
1030 x 700 mm	9104100119	1030 x 700 mm	9104100133
1130 x 700 mm	9104100120	1130 x 700 mm	9104100134
1230 x 700 mm	9104100121	1230 x 700 mm	9104100135
1330 x 800 mm	9104100122	1330 x 800 mm	9104100136
1430 x 800 mm	9104100123	1430 x 800 mm	9104100137
1480 x 800 mm	9104100296	1480 x 800 mm	9104106410
1530 x 800 mm	9104100124	1530 x 800 mm	9104100138
1580 x 800 mm	9104100297	1580 x 800 mm	9104106413
1630 x 800 mm	9104100125	1630 x 800 mm	9104100139
1730 x 800 mm	9104100126	1730 x 800 mm	9104100140
1830 x 800 mm	9104100298	1830 x 800 mm	9104100314
1930 x 800 mm	9104100299	1930 x 800 mm	9104100315



For windows without frames

The roller blind is fitted with a head fixture and has a tab at the bottom for easy use. It provides a simple but effective system as a sun screen and for privacy in the driver's cabin.

- The roller blind can be shortened in width.
- Available with grey or sand-coloured roller blind, each with aluminium coating.

Dometic SEITZ spring roller blind

3.42



Product [W x H] mm	Weight [kg]	Ref. No.	Product [W x H] mm	Weight [kg]	Ref. No.
Spring roller blind, alu-sand			Spring roller blind, grey		
770 x 700 mm	0.45	9104100218	770 x 700 mm	0.45	9104100206
920 x 700 mm	0.51	9104100219	920 x 700 mm	0.51	9104100207
970 x 700 mm	0.53	9104100220	970 x 700 mm	0.53	9104100208
1120 x 800 mm	0.58	9104100221	1120 x 800 mm	0.58	9104100209
1270 x 800 mm	0.65	9104100222	1270 x 800 mm	0.65	9104100210
1320 x 800 mm	0.79	9104100223	1320 x 800 mm	0.79	9104100211
1370 x 800 mm	0.81	9104100224	1370 x 800 mm	0.81	9104100212
1520 x 800 mm	0.88	9104100225	1520 x 800 mm	0.88	9104100213
1620 x 800 mm	0.93	9104100226	1620 x 800 mm	0.93	9104100214
1720 x 800 mm	0.98	9104100227	1720 x 800 mm	0.98	9104100215
1820 x 800 mm	1.03	9104100228	1820 x 800 mm	1.03	9104100216
1920 x 850 mm	1.08	9104100229	1920 x 850 mm	1.08	9104100217



Dometic SEITZ fly screen

Let the fresh air in and keep the insects out – you can do that with the clever, economical fly screen solution from Dometic SEITZ. The aluminium frame is simply attached to the top half of the door, which can be opened separately.

- Durable, powder-coated aluminium frame
- Sturdy, glass-fibre reinforced insect fly screen
- Extremely easy to use
- Low space requirement [only 62 mm deep]
- Available in two standard sizes

Dometic SEITZ fly screen for two-piece entrance doors

3.42

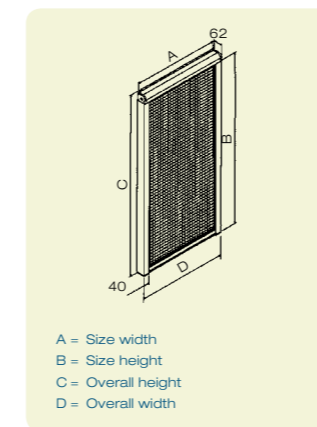

Size A [mm]	Size B [mm]	Size C [mm]	Size D [mm]	Weight [kg]
580	1100	1165	592	2.8
615	1100	1165	627	2.8

Product	Ref. No.
580 x 1100	9104100238
615 x 1100	9104100239

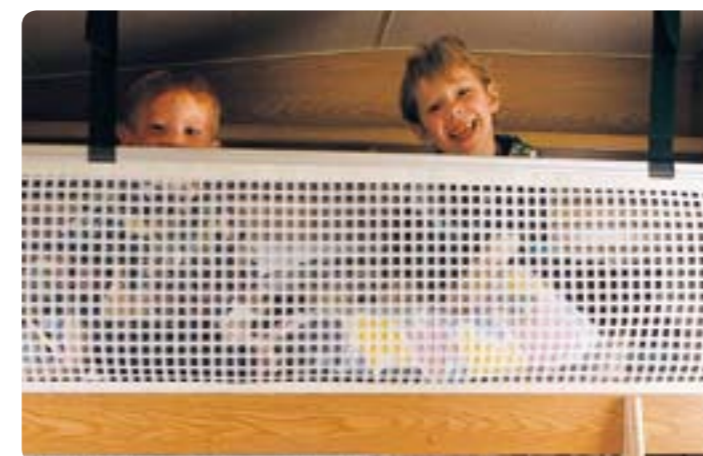

Dometic SEITZ safety net

Children love messing about on the bed. With this safety net, you can rest assured that they will be safe. It is attached to the slatted base with four screws and with two straps on the ceiling and can be dismantled in a matter of seconds.

- Meets the standards of the automobile industry
- For heights of up to 900 mm
- Available in two standard sizes
[W x H]: 1500 x 580 mm and 1800 x 580 mm

Dometic SEITZ safety net

3.42

Product [W x H] mm	Ref. No.
1500 x 580	9104100231
1800 x 580	9104100232



Dometic SEITZ clothes drier

Where do you hang all your wet swimming things and tea towels and the T-shirts and socks you just quickly washed? They quickly dry again on the pull-out adjustable clothes drier from Dometic SEITZ. Three hanging rails and an especially sturdy towel rail are available. Only a small amount of space is required for mounting and when not in use, the clothes drier is easily folded together.

- One aluminium towel rail
- Three galvanised steel, plastic-coated rails
- Aluminium cover for the rails
- Anti-corrosion design
- Can be pulled out and folded away
- Minimum space requirement
- Supplied with two aluminium wall brackets

Dometic SEITZ clothes drier

3.42



Weight	1.05 kg
Sizes [WxHxD]	500 x 50 x 100 mm [folded up] 500 x 50 x 220 mm [extended]
Product	Ref. No.
Clothes drier	9104100230



Dometic SEITZ acrylic glass polish, special cloth and cleaning agent

This cleaning agent for regular cleaning removes all types of dirt, even grease and nicotine film. It prevents static build-up and dust accumulation without using a solvent. Using the acrylic glass polish and a special cloth can remove blind spots and light scratches.

Dometic SEITZ

3.42

Product	Ref. No.
Acrylic glass polish	9104100242
Special cloth	9104100243
Acrylic glass cleaner	9104100244



Dometic SEITZ SK 4 service-hatch

Spray cast from weatherproof ASA. This is fitted in the opening on the vehicle without screws [for vertical and horizontal assembly].

- Equipped with multi-point locking and closing system [except size 375 x 305 mm]
- Suitable for wall thicknesses of 23 to 42 mm
- Available in five different sizes



Dometic SEITZ SK 5 service-hatch

The attractive design of this weather-resistant service hatch blends in to the exterior of your recreational vehicle. No need for screws for this simple assembly. Vertical or horizontal assembly possible.

- Hinges on the inside
- Integrated ventilation for Dometic cassette toilet [360 x 310 mm]
- Secure multi-point locking and closing system
- Available in four different sizes
- Suitable for wall thicknesses of 23–36 mm

Dometic SEITZ SK 4

3.42

Service hatches for your motorhome or caravan

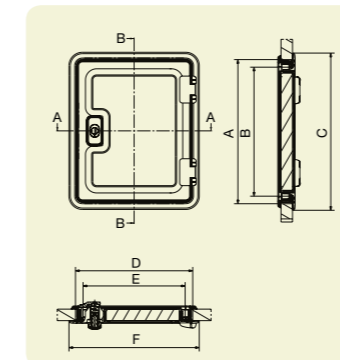

Size	Width size [hinge side]			Height size			Wall thickness	Weight kg*	Ref. No.
	Size A	Size B	Size C	Size D	Size E	Size F			
375 x 305	375	335	409	305	265	338	23–32	0.99	9104100197
700 x 305	700	660	734	305	265	338	23–32	1.45	9104100198
700 x 405	700	660	734	405	365	438	23–42	1.65	9104100199
1000 x 305	1000	960	1034	305	265	338	23–42	2.00	9104100200
1000 x 405	1000	960	1034	405	365	438	23–42	2.20	9104100201

* Weight without cover
All sizes in mm. Changes and errors reserved.
A = Space size in width
B = Clearance in width

C = Overall width
D = Space size in height
E = Clearance size
F = Overall height

Dometic SEITZ SK 5

3.42

Service hatches for your motorhome or caravan

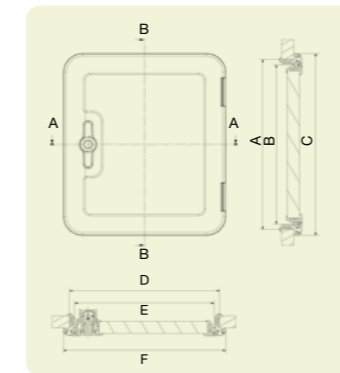

Size	Width size [hinge side]			Height size			Wall thickness	Weight kg*	Ref. No.
	Size A	Size B	Size C	Size D	Size E	Size F			
360 x 310	360	337	385	310	288	335	23–36	0.90	9104100202
650 x 350	648	625	673	348	326	373	23–36	1.30	9104100203
750 x 300	748	725	773	298	276	323	23–36	1.40	9104100204
1000 x 420	998	960	1023	418	396	443	23–36	2.00	9104100205

* Weight without cover
All sizes in mm. Changes and errors reserved.
A = Space size in width
B = Clearance in width

C = Overall width
D = Space size in height
E = Clearance size
F = Overall height



Clean performance!

Powerful, compact and concealed

The central vacuum cleaning system from Dometic is barely the size of a shoebox. And can be so perfectly integrated into unused stowage spaces that only a small "socket" remains visible. The unit switches on automatically when the vacuum hose is inserted into this opening. When the hose is pulled out after the work is done, it switches off and the flap over the socket closes by itself [spring mechanism].

Cleanliness and hygiene on board

The flexible 12-metre hose of the CV 2004 reaches into the furthest corners, and a variety of brushes and nozzles remove the dirt from even the smallest gaps. The innovative triple filter system and the powerful motor also ensure that the air is cleaned efficiently.

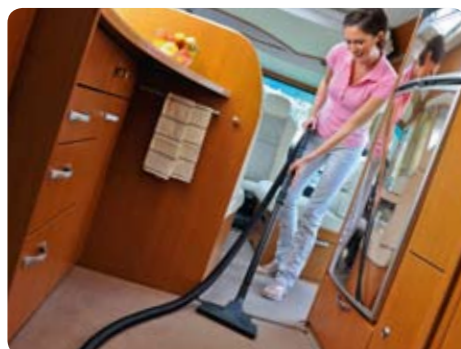

The 12 metre long hose reaches in to the farthest corners.



Invisible from the outside: the vacuum cleaner can be kept in a storage compartment or in the garage.



When the vacuum hose is connected, the vacuum cleaner starts automatically.

Dometic CV 2004

Central vacuum cleaner system for motorhomes

3.31



Features & functions

- Efficient and hygienic thanks to a powerful motor and triple filter system
- Ideal for concealed installation in storage compartments
- Can be installed horizontally or vertically
- Flexible 12-metre hose
- Diverse brushes and nozzles included

Input voltage	230 volts
Current consumption	5.5 A
Power input	1200 watt
Vacuumping performance	2500 mm water column
Material	Plastic housing
Colour	Black
Size [W x H x D]	Front panel: 243 x 460 x 30 mm Housing: 209 x 413 x 100 mm
Weight	3.7 kg

NEW

Concealed installation

Inconspicuous vacuum hose socket

Automatic switch-on when the hose is inserted

Triple filter system

Comprehensive accessories included

Scope of delivery: Central unit, installation accessories, accessory bag, vacuum hose, diverse nozzles and brushes, crevice nozzle, vacuum cleaner bag

Product	Ref. No.
Dometic CV 2004	9103500002
Accessories	
Vacuum cleaner bag [5 pieces]	9103500005



Changing the dust bag: as easy as a vacuum cleaner at home



Series standard: comprehensive accessories for any [suction] situation

Battery-operated wet-and-dry vacuum cleaner

Get rid of that dirt!

The handy vacuum cleaner comes complete with integrated battery – no need for an external power supply. And it's strong enough to get rid of the most ground in dirt. Even liquids are no problem for the combined wet-and-dry cleaner. It doesn't require much room for

storage, either: small and compact, the handy gadget slots in to the boot or vehicle interior, the garage or the storeroom.

WAECO PowerVac PV 100

Wet/dry vacuum cleaner with 12-volt rechargeable battery

3.31



Features & functions

- › Handy, battery-powered vacuum cleaner for mobile use in cars, motorhomes, caravans, boats and home
- › Maximum mobility with rechargeable 12-volt battery
- › Can be recharged from 12 and 230 volts
- › Easy-to-clean dust container and fabric filter
- › Cleaning power: 400 mm water column

Motor	12 volts DC, 28,000 rpm
Battery	12 volts DC, 2.6 Ah
Operating time	approx. 18 min ± 10%
Charging time	10 to 14 h (automatic cut-off)
Capacity	3.8 litres
Power consumption	approx. 90 watts
Cleaning power	approx. 400 mm water column (± 10%)
Operating temperature	0°C to +40°C
Material	Handle: ABS Filter: polyester Dust container: PP
Dimensions (W x H x D)	270 x 320 x 198 mm
Weight	2150 g

Scope of delivery: vacuum cleaner, hose, attachments for upholstery, rugs and narrow gaps, carrying strap, mains adapter, 12-volt charging cable, operating instructions

Product	Ref. No.
PowerVac PV 100	PV-100



Perfect cleaning performance!

The WAECO PowerVac battery gives you 18 minutes of uninterrupted operation. Then it's time to connect it to the mains for recharging. Using the connection that is part of the set, recharging takes between 10 and 14 hours. The process is electronically controlled and completed to prevent overcharging. The vacuum cleaner comes with a 3.8 litre dust container and reusable fabric filter, both of which are simply taken off for emptying and cleaning.

Top cleaning power – minimal power consumption

What many of us don't know is that you can't judge a vac's cleaning power by its watt rating alone. Much more relevant is the generated under-pressure measured in millimetres of water column. This is where the PowerVac scores excellent results. Compared with a 1200-watt high-tech vacuum cleaner, which generates about 1,500 mm of water column, the battery vac achieves a proud 400 mm at a modest power consumption of 90 watts!



Suitable for both wet and dry vacuum cleaning



Brush attachment for doormats, rugs and upholstery



Easy cleaning thanks to detachable dust container and fabric filter



Extendible crevice nozzle for narrow gaps

Good to know you are safe and sound

MagicSafe gas detector

How do you know if gas from an on-board supply has leaked into your vehicle? Probably only when it is too late ... The WAECO MagicSafe gas detector protects you. It reliably detects the presence of narcotic gases in the atmosphere and immediately triggers the alarm: the integrated buzzer emits an audible signal and the red LED blinks. Simultaneously, the output relay is switched on. It can be used to activate external alarm units up to 10 A.

You can silence the audible alarm by pressing a button. The same button can be used to start the sensor's function test. Any system failure will be immediately indicated.

The sensor detects knock-out gases based on ether, chloroform, butane, ethane and trichlorethene. It automatically adjusts to the room atmosphere.

WAECO MagicSafe MSG 150

Gas detector 12 and 24 volts

3.08

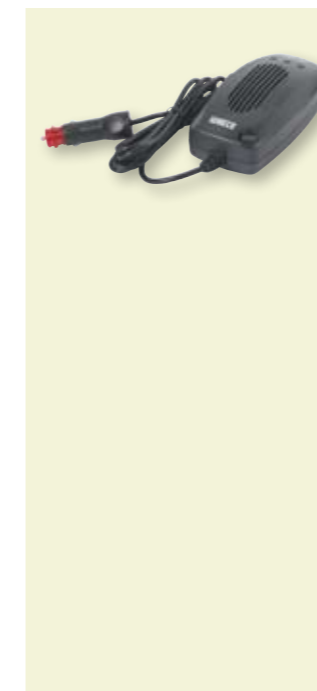

Features & functions

- › Responds to all common narcotic gases
- › Audible and visual alarm
- › Integrated 10-A switching relay
- › Adjusts automatically to the room atmosphere
- › Temperature-independent gas sensor
- › Automatic self test with visual error indication
- › Manual function test
- › Self-cleaning gas sensor
- › Three usage options:
 - As stand-alone unit
 - In combination with WAECO MagicSafe MS 650 and MS 670 car alarms (12 V operation only)
 - In combination with the WAECO MS-620SI siren (12 V operation only)
- › For 12/24-volt power supply

Current input	approx. 80 mA
Control output	1
Output switching current	10 A

Scope of delivery: MSG 150 gas detector, mounting plate, installation and operating instructions

Product	Ref. No.
MagicSafe MSG 150	MSG-150-N
Optional extra Exterior siren (12 V)	MS-620SI

Detects all common narcotic gases

Can be used as stand-alone unit or in combination with the WAECO car alarms MagicSafe MS 650 and MS 670

Audible and visual alarm





A safe bet for storing your valuables

Dometic safes leave no point of attack for thieves and burglars. Laser-cut doors and two 18 mm steel pivots provide safe storage for your valuables while on the move. The ideal security concept for your recreational vehicle - designed by a company that sets the quality benchmarks for hotel safe security worldwide.

Compact and sturdy: the key-locking **mechanical models Dometic SAFE 281C and 361C** provide many features for enhanced security.

- Mechanical locking system
- Laser-cut doors and frames
- Tight tolerances between door and frame
- Door locking with two 18 mm steel pivots
- Flexible installation: horizontal or vertical
- Available in two sizes: compact safe or laptop size

Extra security: the two **automatic models Dometic SAFE MD 281C and MD 361C** meet highest demands in terms of operating comfort and design.

- Automatic motor locking
- Electronic locking by code entry with 5-minute memory function
- Illuminated LED display
- Emergency access with masterkey
- Laser-cut doors and frames
- Tight tolerances between door and frame
- Door locking with two 18 mm steel pivots
- Flexible installation: horizontal or vertical
- Available in two sizes: compact safe or laptop size

Dometic SAFE 281C / 361C

Safes with mechanical locking system
For secure storage of valuables in vehicles

3.34



	281C	361C
Capacity	8.3 litres	24.5 litres
Net weight	6.5 kg	12.7 kg
Dimensions [W x H x D]	280 x 165 x 235 mm	360 x 190 x 410 mm
Steel wall thickness	Door: 5.0 mm, cabinet: 1.5 mm	
Colour	Anthracite	
Quality features	Laser-cut door, very tight tolerances between door and cabinet, door locking with 2 steel pivots, robust inside hinges and locks without any plastic parts, vertical or horizontal installation	
Certification	RoHS	

Scope of delivery: safe, 2 keys, operating instructions

Product	Ref. No.
SAFE 281C	910660001
SAFE 361C	910660002
Optional extra Fixing kit	910660005

- Mechanical locking system
- High-grade finish for maximum security
- Easy key operation
- Dometic SAFE 361C in laptop size

Dometic SAFE MD 281C / MD 361C

Safes with automatic locking system
For secure storage of valuables in vehicles

3.34



	MD 281C	MD 361C
Capacity	8.3 litres	24.5 litres
Net weight	6.5 kg	12.8 kg
Dimensions [W x H x D]	280 x 165 x 235 mm	360 x 190 x 410 mm
Steel wall thickness	Door: 5.0 mm, cabinet: 1.5 mm	
Colour	Anthracite	
Quality features	Automatic motor locking system [battery-powered], electronic locking with 4-digit code [changeable] and 5-minute memory function, battery-low indication, laser-cut door, very tight tolerances between door and cabinet, door locking with 2 steel pivots, vertical or horizontal installation	
Certification	RoHS, EMC	

Scope of delivery: safe, 2 emergency access keys, plastic door knob, 4 Duracell batteries, operating instructions

Product	Ref. No.
SAFE MD 281C	910660003
SAFE MD 361C	910660004
Optional extras Aluminium door knob	910660006
Fixing kit	910660005

- Automatic locking system
- Electronic locking by code entry with 5-minute memory function
- Attractive design with illuminated LED display
- High-grade finish for maximum security
- Dometic SAFE MD 361C in laptop size



No point of attack for burglars: laser-cut doors and frames

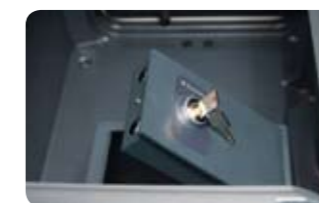

Flexible installation: vertical or horizontal



Functional aesthetics: illuminated LED display on MD 281C and MD 361C safes



Practical laptop size: Safes 361C und MD 361C

15" laptop size